



# Trapped Key Interlocks for Switchgear





## Applications Guide



The Future of Safety is Here



-  Castell Offices
-  Castell Installations

**We Keep You Safe at Work  
Worldwide**

## Contents

Why Choose Castell	4
Interlocking Switchgear	5
How to Design an Interlock System	6
Incomer Interlocking	7
Incomer and Busbar Interlocking	9
Incomer, Generator and Busbar Interlocking	10
Transformer Interlocking	10
Power Factor Correction Equipment/Capacitor Bank Interlocking	11
Wind Farm	12
UPS (Uninterruptable Power Supply)	12
Electrostatic Precipitators (ESP)	13
OEM Equipment	14
Switchgear Symbols	17
Products Overview	18

# Why Choose Castell?



**Founder:**  
James Harry Castell  
1880 - 1953

## Castells Expertise in Industrial Safety

The original Castell interlock concept dates from 1922 and was developed for the electrical switchgear industry. For over 90 years Castell delivers solutions across the electrical network from power stations to transmission equipment and from sub stations to incomer rooms.

The ability to work across HV, MV and LV means that a Castell system can be used as a single solution to provide personnel safety and ensure equipment is used in the correct mode.

Working closely with key switchgear manufacturers has enabled Castell to produce interlocks designed specifically for use on the leading manufacturers own breakers, isolators, disconnectors and earth mechanisms.

That makes Castell trapped key interlocks be the perfect choice for protecting personnel in the switchgear environment.

## Castell Offers:

- Expertise in providing the best possible trapped key solution whatever the industry
- 90 years of experience protecting people and assets in industry
- High quality innovative products
- ISO 9001: 2008 accreditation
- Global team dedicated to providing technical support and assistance in selecting the correct solution
- The widest range of rugged and reliable trapped key interlock products globally
- The ability to produce customised solutions to meet the demands of your specific application
- Safety solutions that last for decades

## Interlocking Switchgear

Interlocking switchgear ensures that personnel remain safe and equipment is operated to the correct procedures. Using a well-designed interlocking scheme will ensure that personnel cannot access potentially dangerous areas without the switchgear system being put in a safe state. A good interlocking scheme will also ensure that the system operates correctly and there is no chance of, for example, switching two incoming feeds on to a common bus bar. This ensures that the equipment is not damaged and the risk of fire and arc flash are greatly reduced.

Processes where interlocking in switchgear are particularly relevant are:

- Personnel access
- Earthing systems
- High, medium and low voltage hazards
- Switching incomers on to common supply busbars
- Switching UPS systems and generators on to common supply busbars
- Controlling the supply from multiple incomers

The schemes in this application guide are for reference only and the overall system should be designed and reviewed by a competent electrical engineer.

## Castell products are used in the following areas:



- LV Distribution & Busbar Systems
- HV Transmission & Distribution Sub Stations
- Transformer Isolation & Earthing Systems
- Generator Systems
- Wind Turbine Isolation & Earthing
- Rail Electrification Systems
- Electrostatic Precipitators
- UPS Systems

Castell has developed products to suit the following companies' equipment:

ABB | Alstom | Terasaki | Schneider Electric | Siemens | Hawker Siddeley | George Ellison | Merlin Gerin

## How to design an interlock system?

Through development and experience Castell have a number of methods to isolate switchgear. This can be done mechanically, through control circuitry or through power circuitry. In complex operations a number of isolations may need to occur to ensure the plant is safe to work on. The isolation key(s) are then used to either gain direct access, are transferred to a time delay unit or for multiple entry points access through an exchange box.

## The three points of trapped key interlocking

### 1 Isolation

### 2 Key Exchange

### 3 Access Control

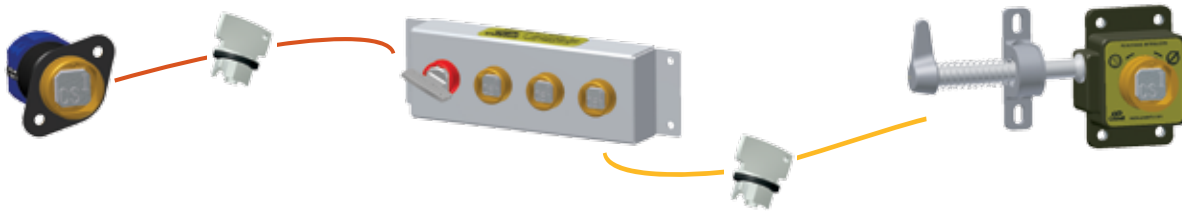

## Access and Personal Protection

Access to the hazardous area needs to be assessed as either part body (arm only), or full body access. Once this is determined an access lock(s) can be selected.

### Part Body Access

A part body access lock has only one lock and the isolation key is used to open this. Whilst the access lock is open the key can not be removed and therefore the process can not be started. Only once the lock is closed can the isolation key be removed and the process restarted.

### Full Body Access

Full body access locks have two locking mechanisms; the first step in the process is to insert the isolation key. This will allow the personnel key to be removed and then access can be granted by opening the bolt. The isolation key can only be removed once the personnel key has been inserted. Therefore whilst the personnel key is removed and the lock is open the process can not be started. Only once the lock is closed and the personnel key returned can the isolation key be removed and the process restarted.

## Coding a System

The coding of the system is an important aspect of the design as this ensures the integrity and safety of the interlocking system. Castell's trapped key interlocks allow for in excess of 50,000 combinations. With this level of available codes entire factories and plants can have trapped key systems with out codes being repeated. It is highly recommended that each site keeps a record of the key codes to ensure that codes are not reused in areas of the site. The isolation, access and personnel keys all need to be coded differently so the process of safe access is ensured. For example in a simple system code 'A' is used for isolation key, this is then transferred to the exchange box where the code 'B' keys are released for access, 'C' keys are then released from the Access Locks for personnel keys. Coding in this way ensures the access process can not be short cut and the system has integrity.

## Incomer Interlocking (1)

### Operation

This system will require three locks and two keys. Under normal operation the two keys are trapped with the switches closed so the incomers are supplying.

The system will allow an incomer to be opened (disconnected) and the key released. This key is then transferred to the open bus coupler which can then be closed.

The system ensures that either only two incomers or only one incomer and the busbar are supplying at any time.

The symbols used here are all symbol A.

\* All locks can be individually fitted to suit the switchgear

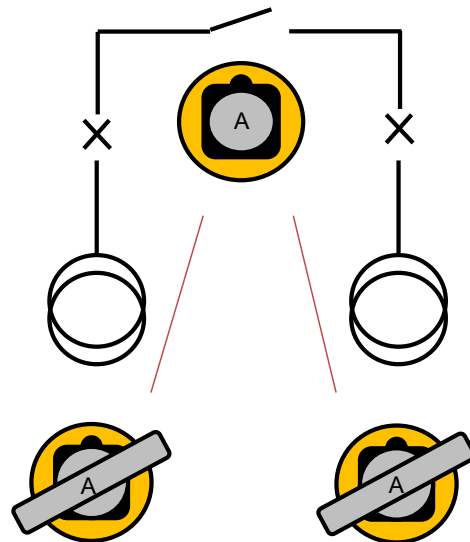

## Incomer Interlocking (2)

### Operation

This system will require three locks and two keys. Under normal operation the two keys are trapped with the switches closed so the incomers are supplying.

The system will allow an incomer to be opened (disconnected) and the key released. This key is then transferred to in to the other open incomer which can then be closed.

The system ensures that only two incomers are supplying at any time.

The symbols used here are all symbol A.

\* All locks can be individually fitted to suit the switchgear

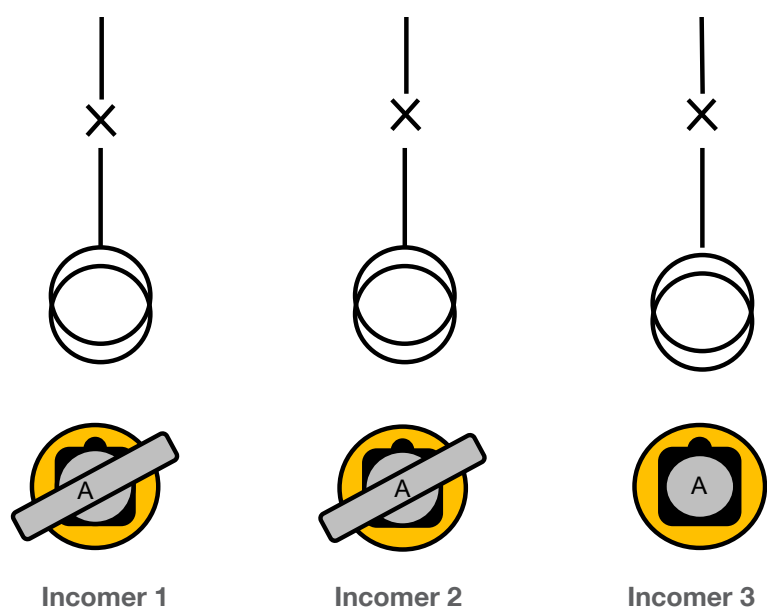

## Incomer Interlocking (3)

### Operation

This system will require six locks depending on the breakers. One key exchange box and six keys.

Breakers A and B are closed and the keys are trapped. Keys A and B are removed from the breakers when they are opened and inserted into the key exchange box releasing the C keys.

The C keys are then inserted in the C locks, closing breakers C.

The symbols used here are A, B and C for the incomers.

\* All locks can be individually fitted to suit the switchgear

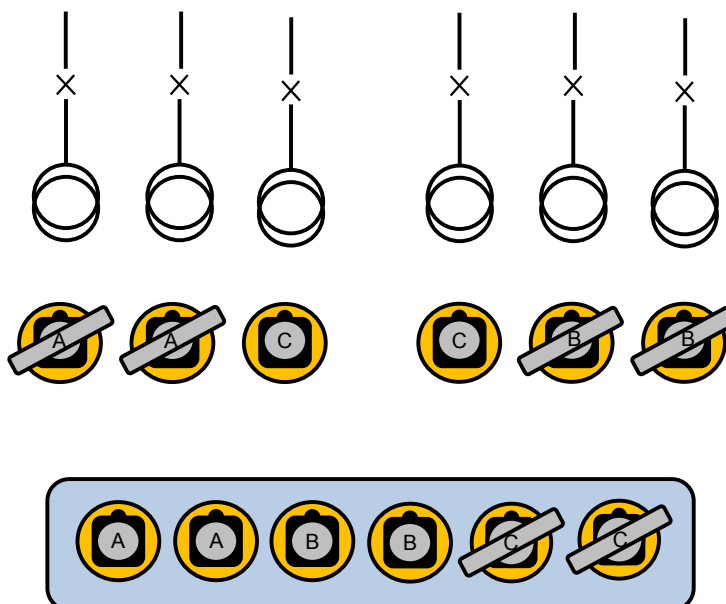

## Incomer Interlocking (4)

### Operation

The operation is shown with all incomers closed, the bus coupler open and its key A21 trapped in the W Selector Box.

To change to position 1 from normal, incomers with symbols A19 are inserted and trapped in the W Selector Box. The asterisks denote that incomers three and four remain closed and need not be returned to the box. Key A21 can now be removed to close the bus coupler switch.

To change to position 2 from normal, incomers with symbols A20 are opened and their keys are inserted and trapped in the W selector box. The asterisks denote that incomers 1 and 2 remain closed and need not be returned to the box. Key 21 can now be removed to close the bus coupler switch.

The symbols used here are A19 and A20 for the circuit breakers and A21 for the bus coupler.

\* All locks can be individually fitted to suit the switchgear

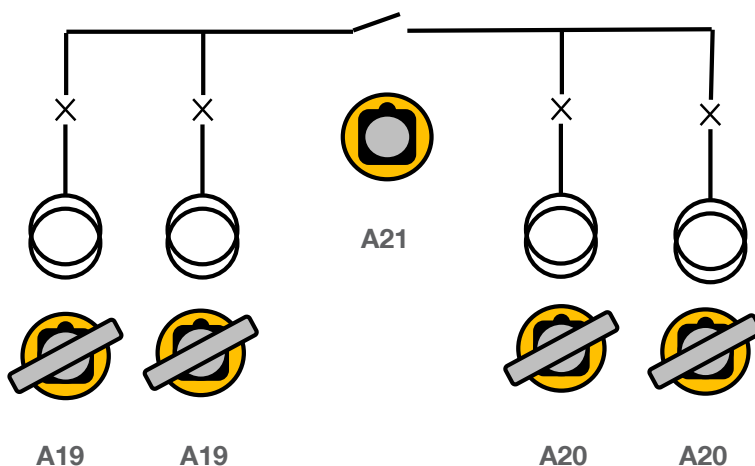

Position	Inc 1 A19	Inc 2 A19	Inc 3 A20	Inc 3 A20	BC A21
1	T	T	F	F	F
Normal	F	F	F	F	T
2	F	F	T	T	F

\* In neighbouring positions only where the key is free in both positions the key does not need to be returned to the key exchange box.

## Incomer and Busbar Interlocking (1)

### Operation

This system requires five locks and three keys. In the normal operation the keys are trapped in the incomers in the closed position and both bus couplers are open.

The symbol sequence will allow appropriate incomers to be open allowing the key to be released, transferred and inserted and trapped to the associated bus coupler allowing it to be closed.

The symbols used here are AA, AB and BB for the Incomers and A\_ (A BLANK) and \_B (BLANK B) for the bus couplers.

\* All locks can be individually fitted to suit the switchgear

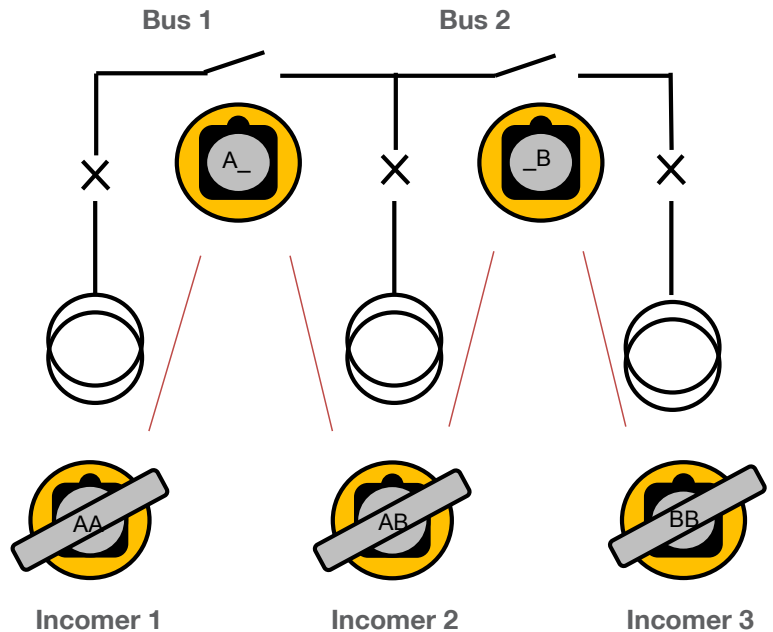

## Incomer and Busbar Interlocking (2)

### Operation

This system will require four locks and two keys. In the situation shown the keys are trapped in incomer one and two with the switches in the closed position.

Both the bus coupler and incomer three are open.

The symbol sequence will only allow incomer 3 or the bus coupler to be closed after the appropriate key has been released, transferred and inserted into the bus coupler or incomer three lock.

The system ensures that only two incomers are supplying at any time.

The symbols used here are AA and AB for the incomers and A\_ (A BLANK) for the bus coupler.

\* All locks can be individually fitted to suit the switchgear

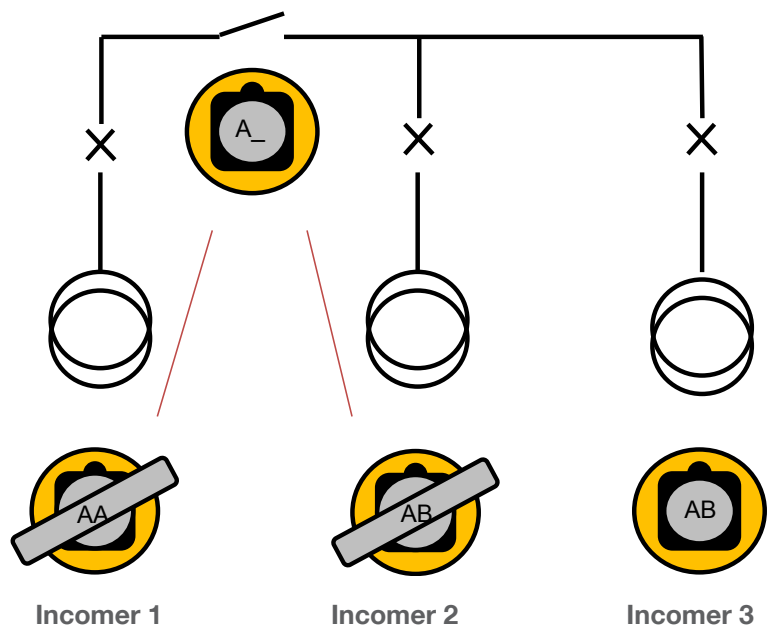

## Incomer, Generator and Busbar Interlocking

### Operation

The normal operation is the 2 incomers are closed with bus coupler and generator are both open. The symbol arrangement using key symbols AA, AB, A\_ (A Blank) on locks with just keys AA AB will ensure safe switching operation. It will not be possible to have Incomer 2 and Generator closed at the same time to avoid paralleling.

The symbols used here are AA and AB for the incomers and A\_ (A BLANK) for the bus coupler.

\* All locks can be individually fitted to suit the switchgear

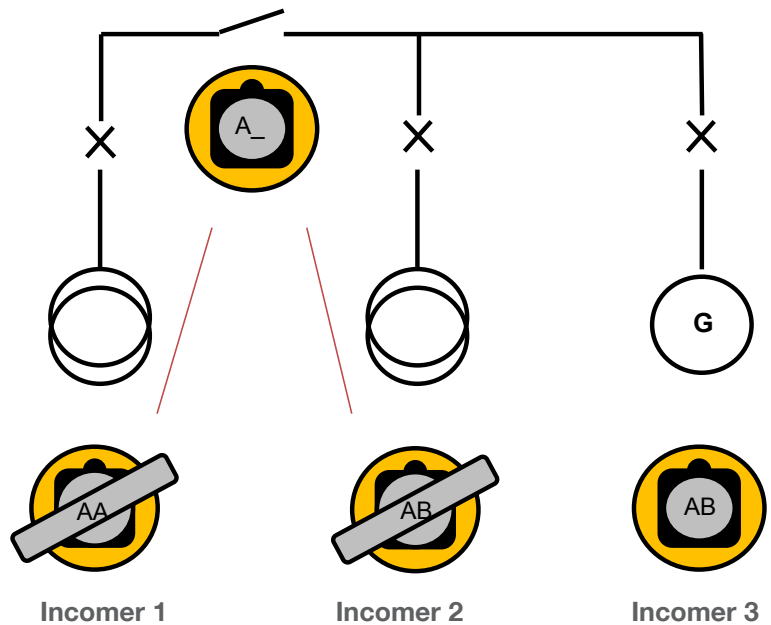

## Transformer Interlocking (1)

### Operation

Whilst the disconnector is on the A key cannot be removed. Switching the disconnector to the off position will allow the A key to be removed from the K Lock.

This A key can then be inserted into the K Lock which will retract the bolt and allow the earthing to be switched on.

This will in turn allow the key B to be removed extending the bolt and locking the earthing in to the on position.

The B key can now be used to gain access through AIE. A personnel key will be released to ensure that the operation cannot be reversed whilst personnel are in the transformer housing.

The symbols used here are A for the disconnector and earthing and B for the earthing and the access lock.

\* All locks can be individually fitted to suit the switchgear

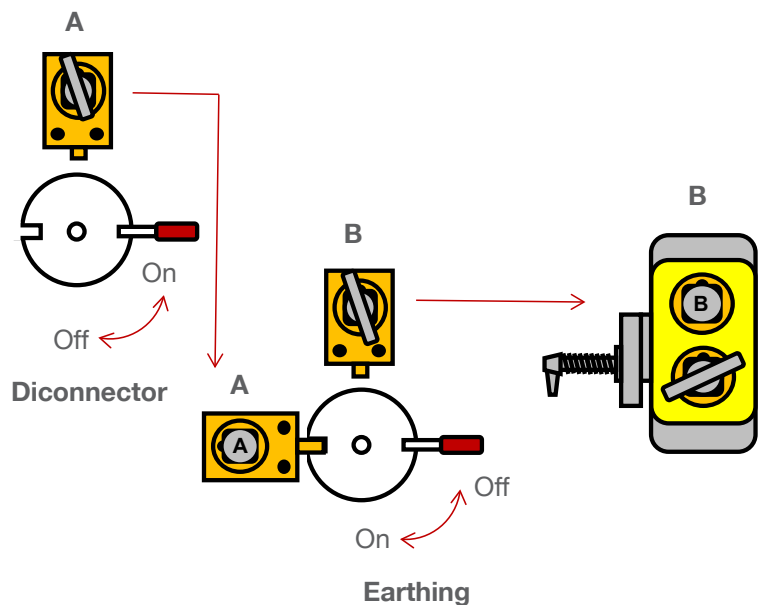

## Transformer Interlocking (2)

### Operation

The HV and LV Isolators are both closed with their respective keys trapped and the transformer door is closed. Both the HV and LV isolators are opened releasing the keys. These keys can then be used in the AIE to give access to the transformer.

The symbols used here are HV and LV for both breakers.

\* All locks can be individually fitted to suit the switchgear

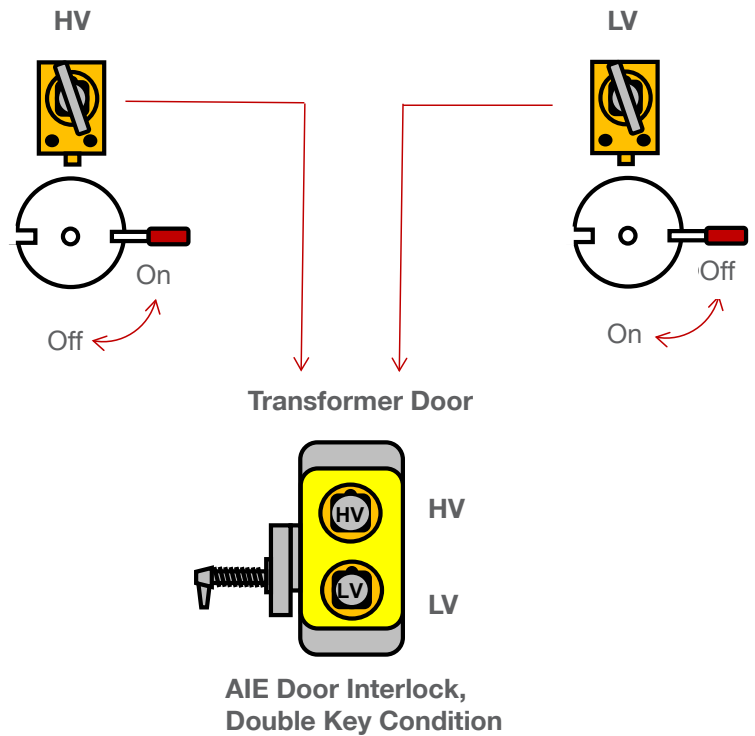

## Power Factor Correction Equipment / Capacitor Bank Interlocking

### Operation

When the HV circuit breaker is closed access can not be gained to the PFC equipment as the A key remains trapped.

When the HV circuit breaker is open the A key can be removed and inserted in to the TDI time delay unit. After a preprogrammed time the B keys are released and these can be used to gain access to the PFC equipment.

The symbols used here are A for the circuit breaker and B for the access locks.

\* All locks can be individually fitted to suit the switchgear

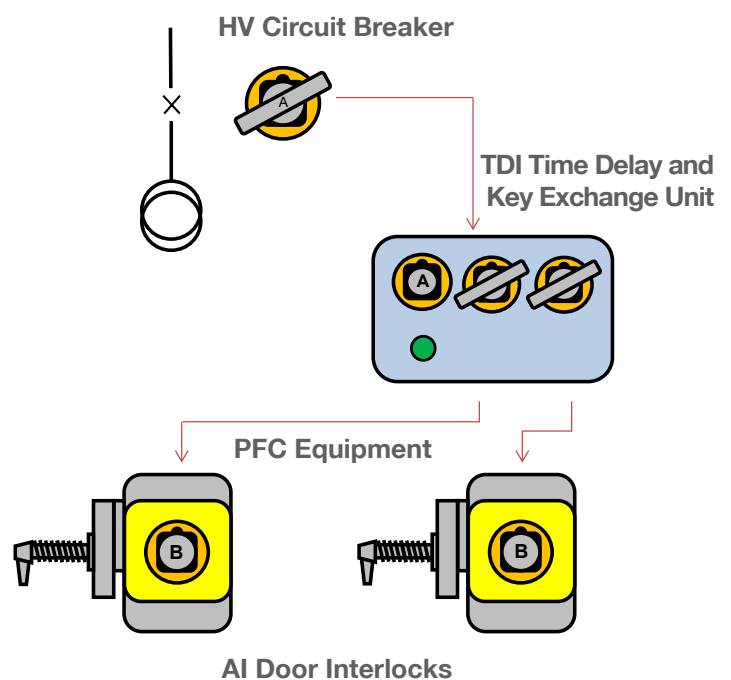

## Wind Farm

### Operation

When the wind turbine is running and generating electricity the keys are trapped in the HV and wind turbine circuit breaker and access can not be gained to the transformer housing.

When the wind turbine and HV circuit breakers are open the keys can then be inserted in to the exchange bow releasing the transformer housing key. This is then inserted in to the AI to gain access to the housing.

The symbols used here are A and C for the circuit breaker and B for the access lock.

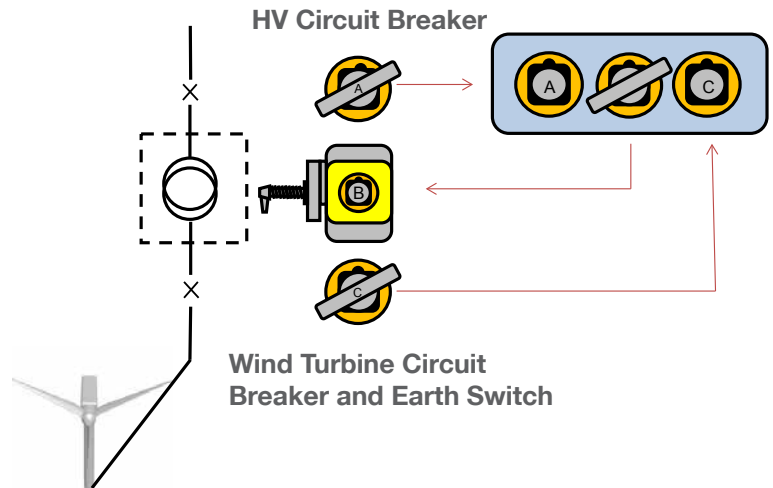

\* All locks can be individually fitted to suit the switchgear

## UPS (Uninterruptable Power Supply)

### Operation

While the UPS is running, the key is trapped in the KSUPS Interlock. The key can only be turned and released when the UPS is put into Bypass. This will energise the solenoid via a remote signal from the UPS system.

Turning the key changes the condition of the switch and released the key, which can now be transferred to the AIE access interlock. This allows access to the UPS for maintenance.

The UPS will remain in a safe state until the key is returned from the AIE and inserted back into the KSUPS and trapped. This allows the UPS to be returned to service.

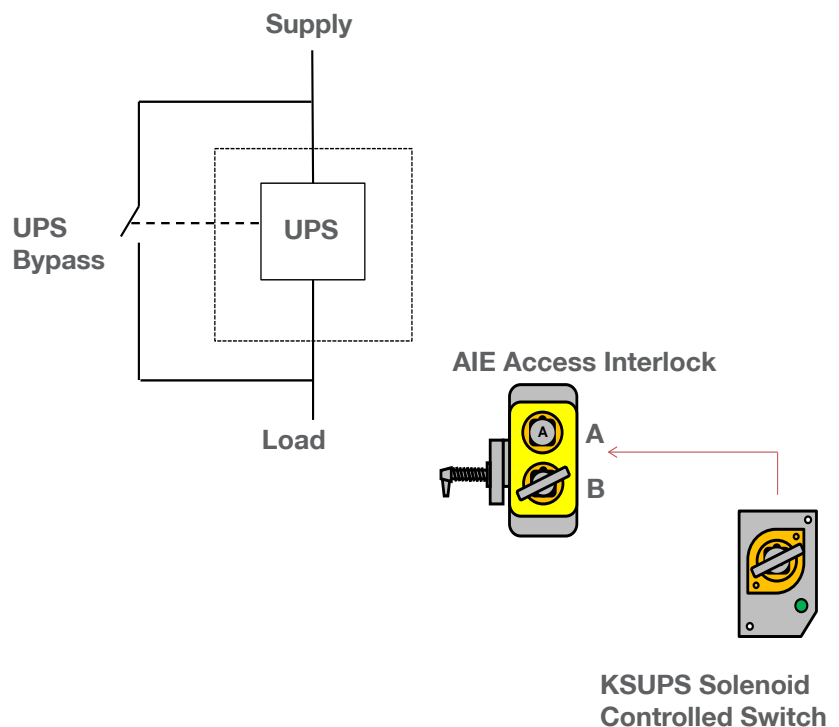

\* All locks can be individually fitted to suit the switchgear

## Electrostatic Precipitators

### Operation

The precipitator environment is a very harsh environment in terms of exposure to the elements and the risk that precipitators present with electrodes carrying in excess of 10,000 volts.

The process for isolating precipitators is to firstly isolate the circuit breaker, this will then allow the removal of the circuit breaker key A. The circuit breaker key A is then used to isolate the transformer, when the transformer is isolated the circuit breaker key remains trapped, therefore preventing the circuit breaker returning to the live state. Locking the circuit breaker key in the transformer allows the removal of the transformer key B. The transformer key B is then used in an exchange box. The exchange box allows multiple keys C to be released so access can be gained to multiple areas. These keys can only be released when the transformer key is locked in position. When access is gained the keys from the exchange box remain trapped in the access locks, this effectively ensures that no power to the electrodes can be turned on whilst access is gained.

To turn on the circuit breaker the process is simply reversed.

In this example the circuit breaker key is symbol A, The transformer is symbol A and B and the access keys are all symbol C.

\* All locks can be individually fitted to suit the switchgear

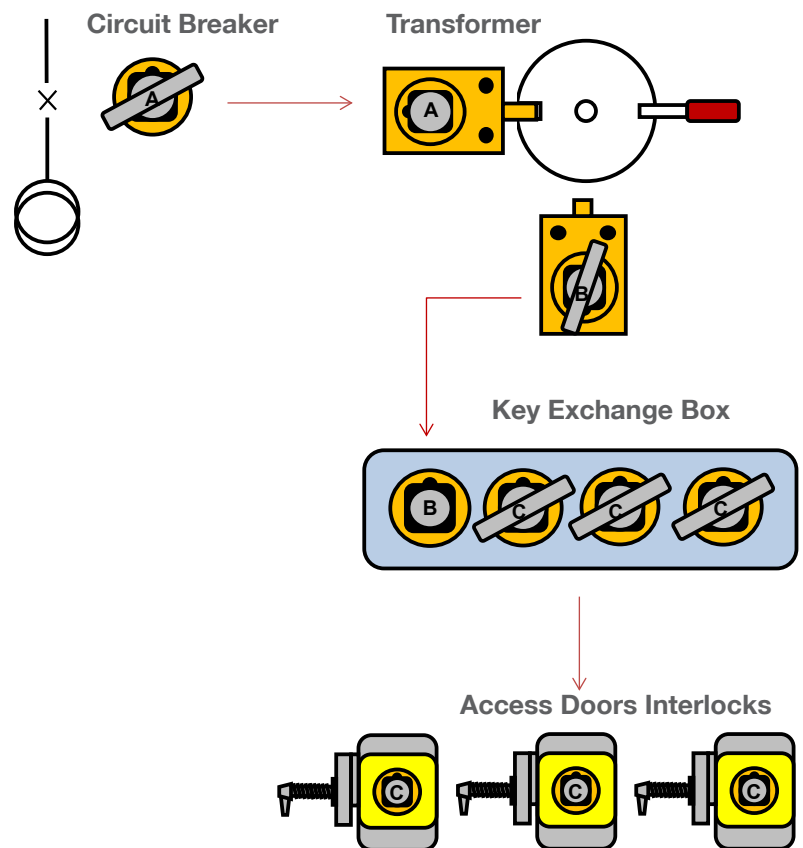

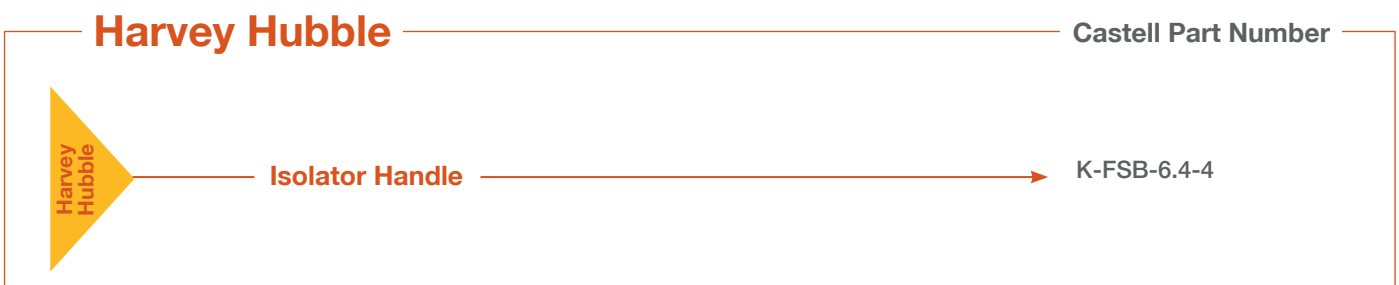
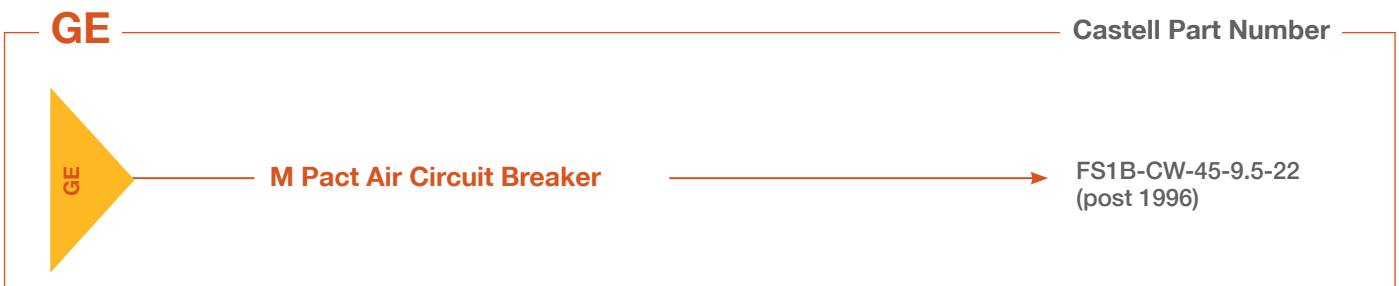
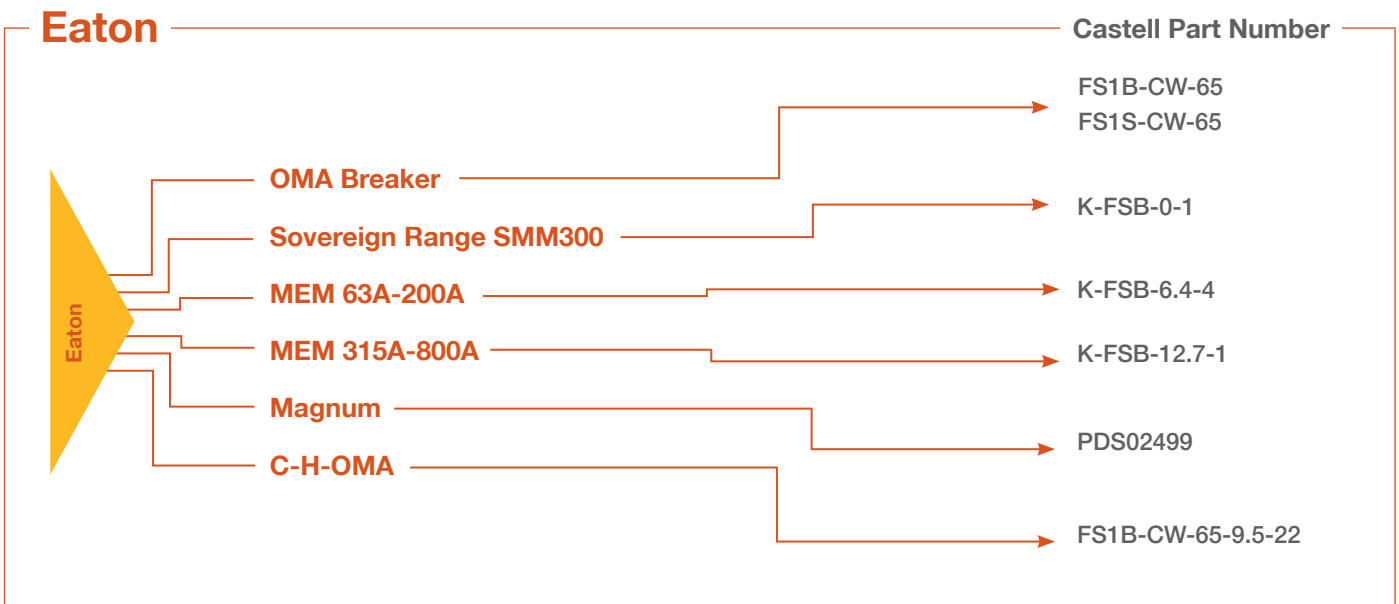
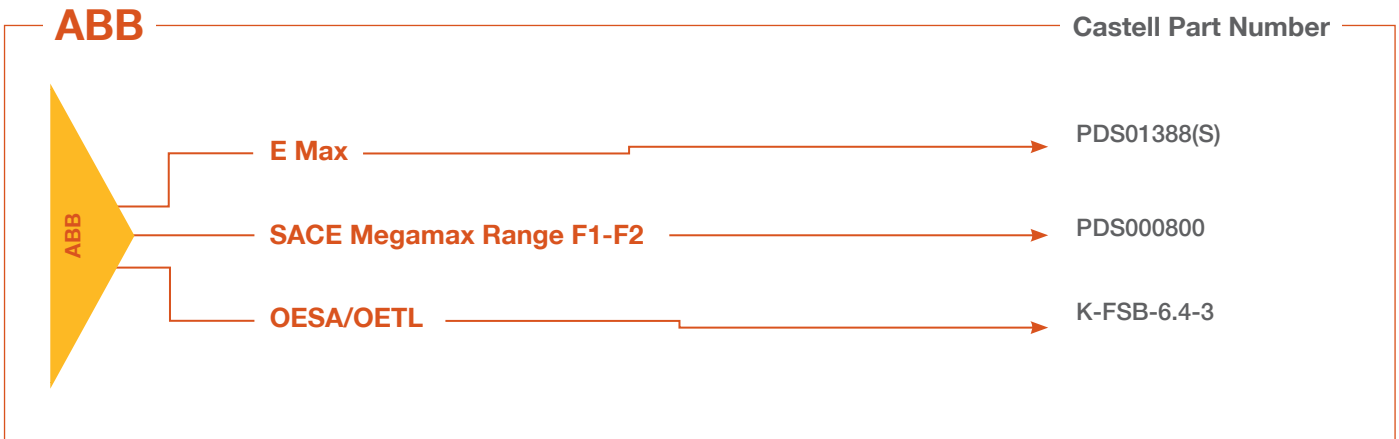

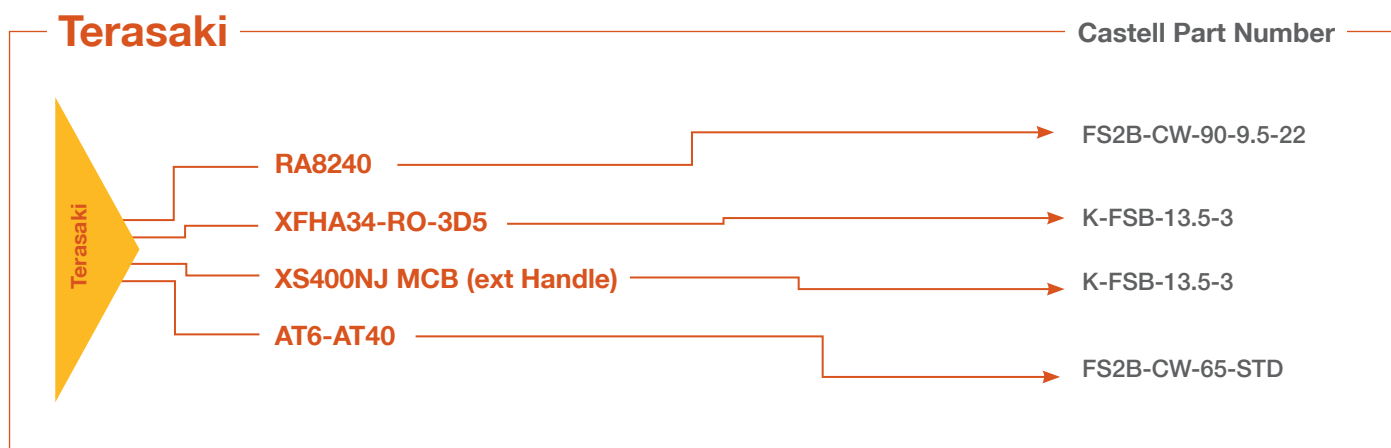
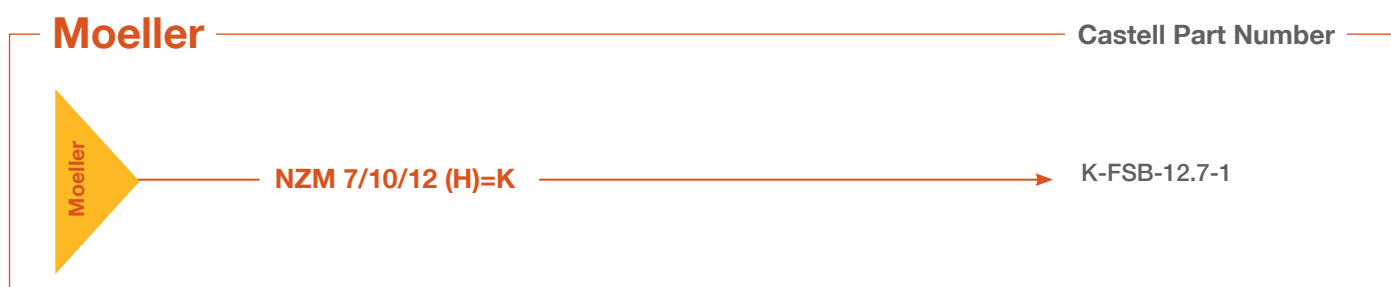
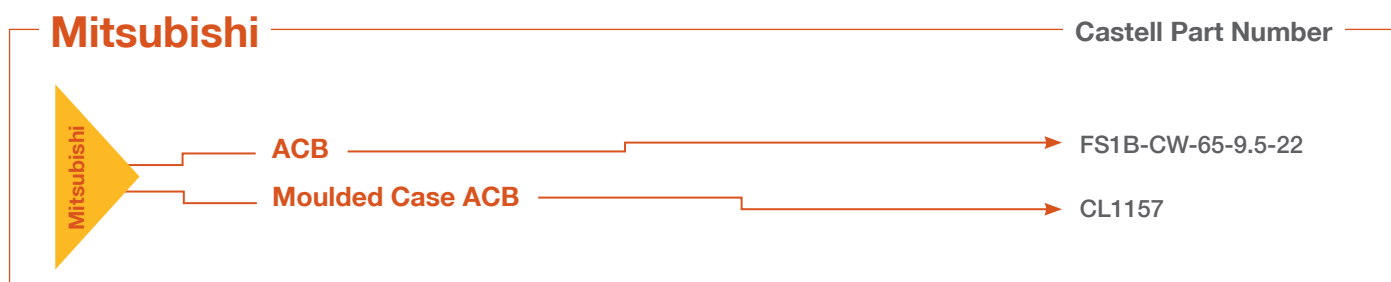
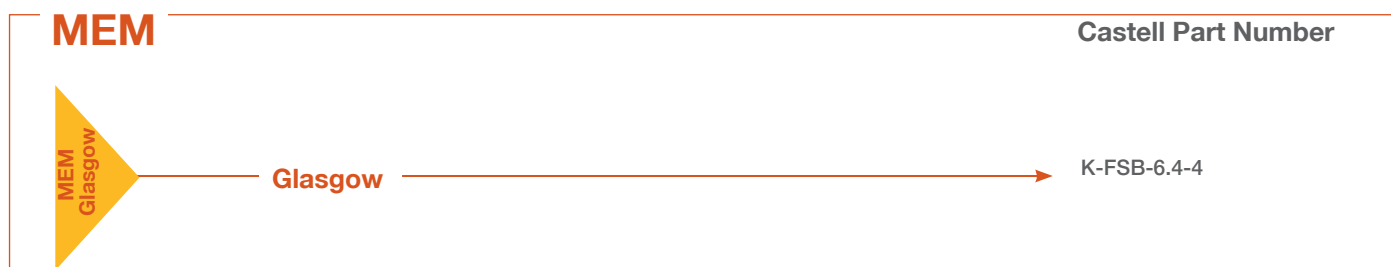

## Socomec

### Castell Part Number

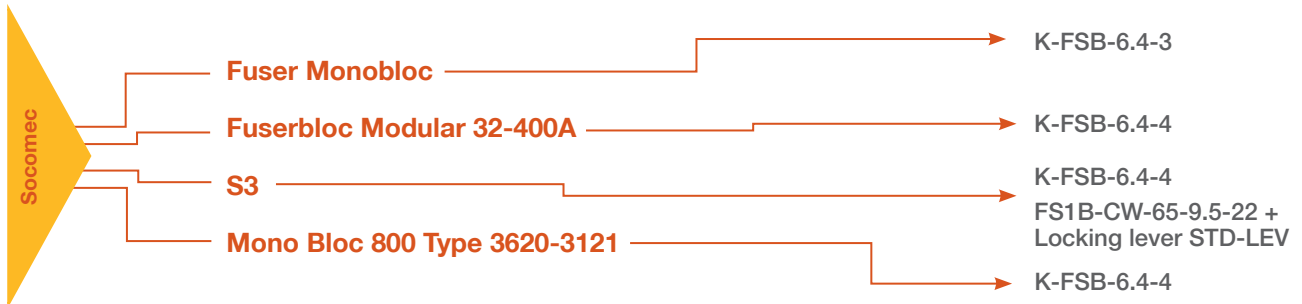

## Siemens

### Castell Part Number

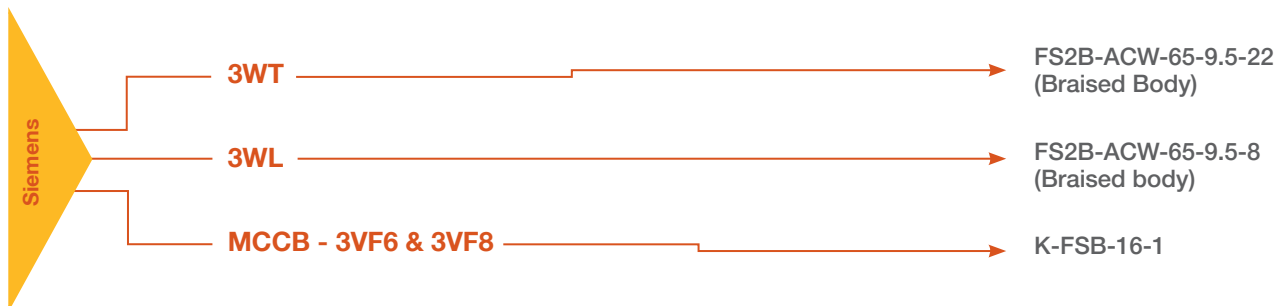

## Schneider

### Castell Part Number



## Common Switchgear Symbols

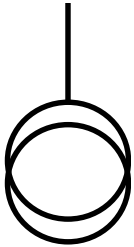

Transformer



Breaker

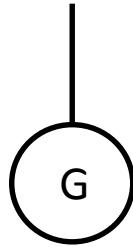

Generator

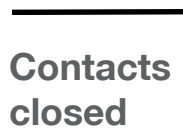

Contacts closed

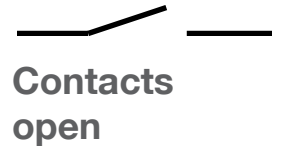

Contacts open



FS Lock, key free



FS Lock, key trapped

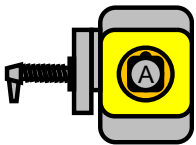

AI Access Interlock

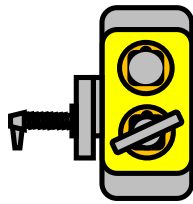

AIE Access Interlock, personnel key trapped



K Bolt Interlock

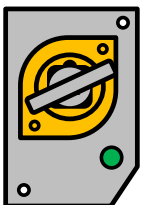

KSUPS Solenoid Controlled Switch



Key Exchange Box

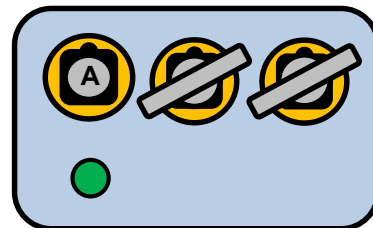

TDI Time Delay Interlock

# Products Overview

## Control Switching

KS



## Solenoid Controlled Switching

KSUPS+



## Time Delay Interlocking

TDI



## Mechanical Isolation

FS / Q



K



## Key Exchange Boxes

X



Y



Z



W



## Part Body Access

AI



## Full Body Access

AIE







Tel: 902 88 25 60  
Barcelona – Madrid – Alicante – Burgos – Pamplona – Valencia – Bilbao – La Coruña – Santander – Sevilla  
info@aqdindustrial.es  
www.industrialproduct.es  
www.aqdindustrial.es

A HALMA COMPANY

